

KEY PLAN

② - ④ DENOTES SHEET NUMBER REFERENCE

REF: 3936BE29

VERSION: 2 (11-11-2019)



CRA SURVEY PTY LTD

LAND SURVEYORS TOWN PLANNERS
DEVELOPMENT CONSULTANTS

7A/346 Belmore Road office@crsurvey.com.au
Balwyn Vic 3103 Tel: 03 9890 0933

SCALE
1 : 1000

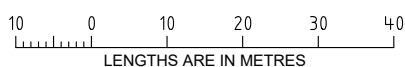

ORIGINAL SHEET
SIZE: A3

SHEET 1 OF 5

RIVERWALK RELEASE 29
BUILDING ENVELOPE PLAN

- Ⓐ BUILDING ENVELOPE BOUNDARY PROFILE TYPE
- 2 SETBACK MINIMUM REQUIRED (IF NONE SHOWN, A BUILDING CAN BE CONSTRUCTED ON THE BOUNDARY PROVIDED THAT THE BUILDING HEIGHT AND LENGTH REQUIREMENTS ARE MET)

2901 LOT NUMBER
 ----- 3 METRE WIDE EASEMENT
 ----- 2 OR 2.5 METRE WIDE EASEMENT

PS828101D

DESIGNATED VEHICLE CROSSOVER TO LOT (NO OTHER VEHICULAR ACCESS POINT IS PERMITTED TO A LOT, EXCEPT WITH THE APPROVAL OF DEVELOPMENT VICTORIA AND WYNDHAM CITY COUNCIL)

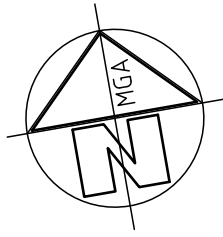

- BUILDING ENVELOPE (GROUND FLOOR)
- BUILDING ENVELOPE (FIRST FLOOR)

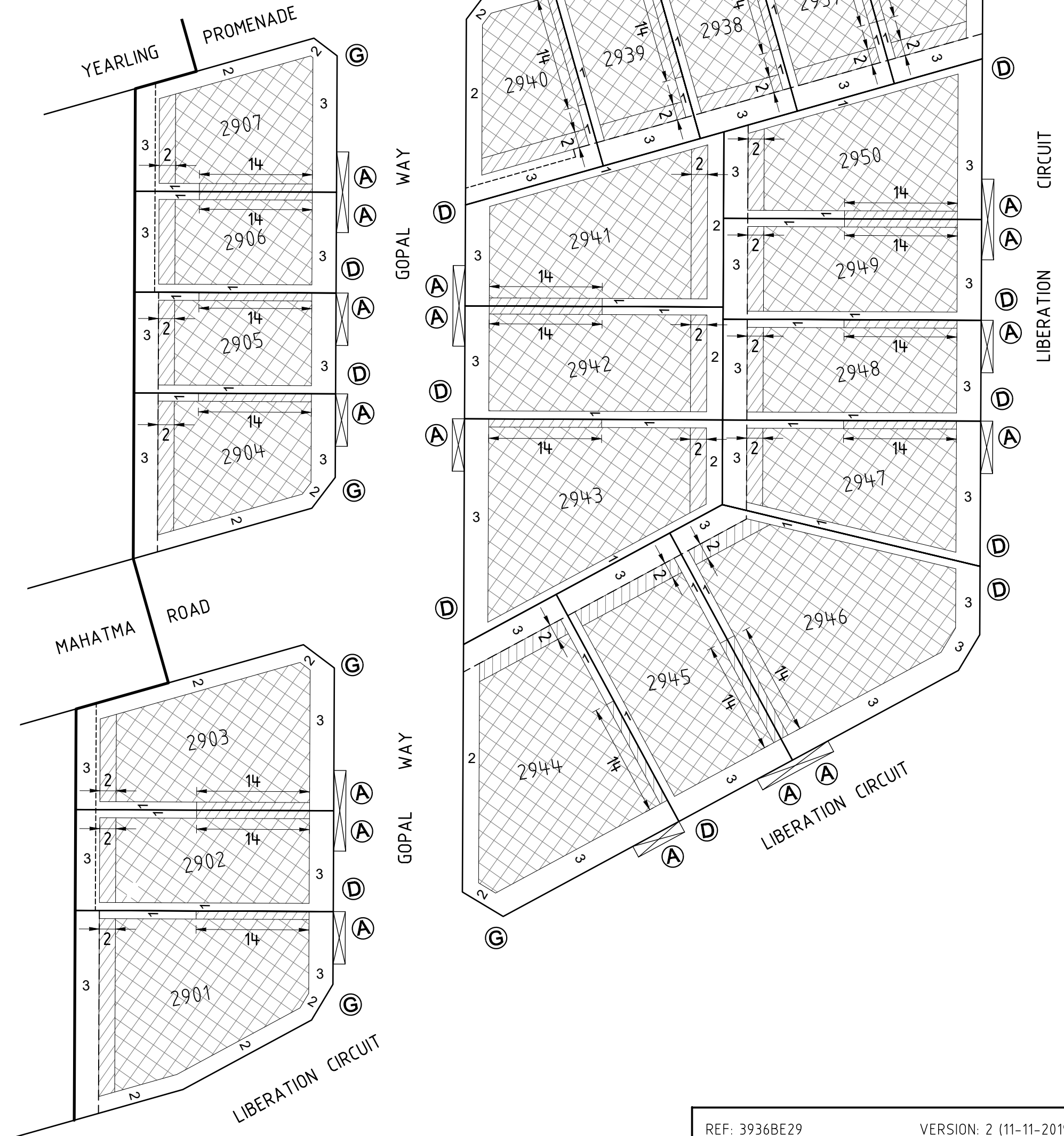

REF: 3936BE29

VERSION: 2 (11-11-2019)



CRA SURVEY PTY LTD

LAND SURVEYORS TOWN PLANNERS
DEVELOPMENT CONSULTANTS

7A/346 Belmore Road office@crsurvey.com.au
Balwyn Vic 3103 Tel: 03 9890 0933

SCALE
1:400

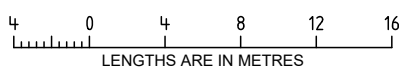

ORIGINAL SHEET
SIZE: A3

SHEET 2 OF 5

**RIVERWALK RELEASE 29
BUILDING ENVELOPE PLAN**

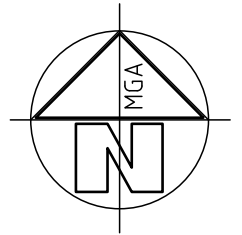

SEE BELOW RIGHT

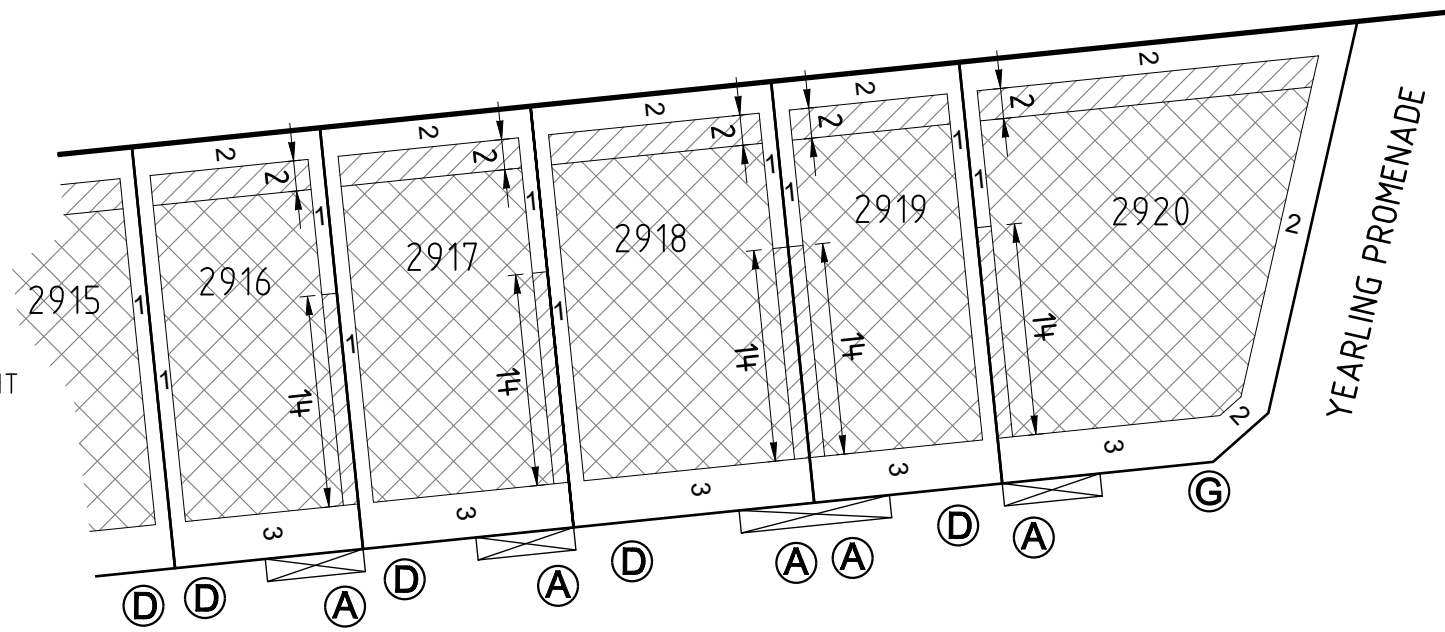

SEE ABOVE LEFT

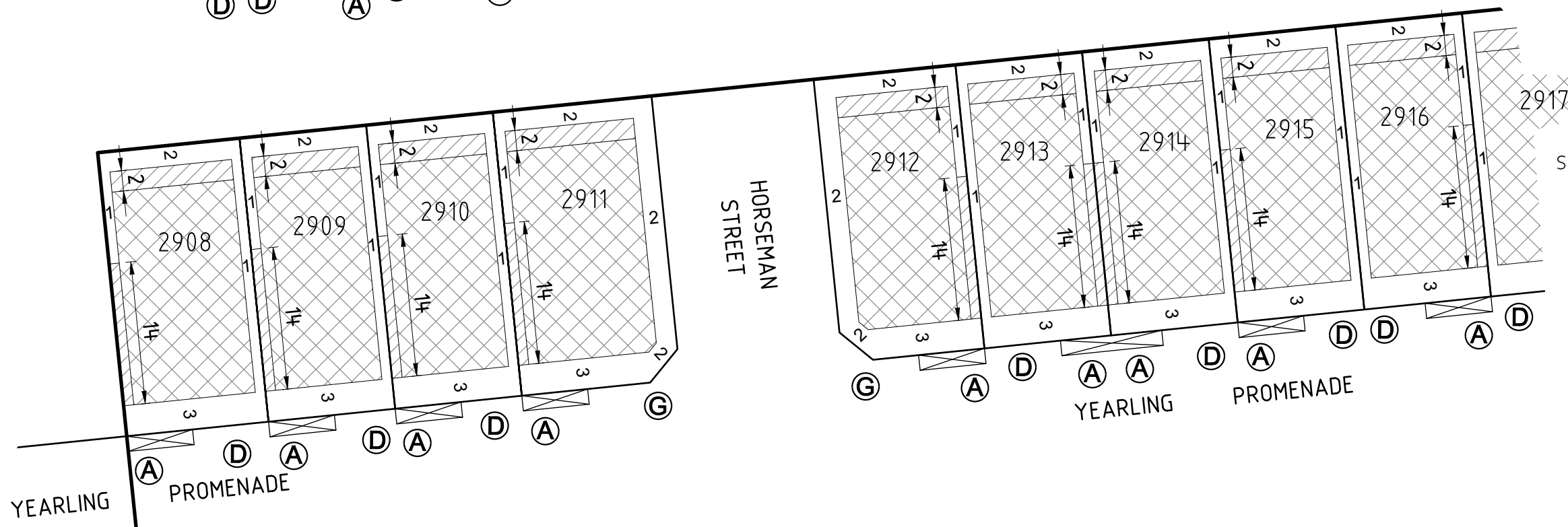

 BUILDING ENVELOPE (GROUND FLOOR)

 BUILDING ENVELOPE (FIRST FLOOR)

----- 2 OR 2.5 METRE WIDE EASEMENT

----- 3 METRE WIDE EASEMENT

2801 LOT NUMBER

(A) BUILDING ENVELOPE BOUNDARY PROFILE TYPE

2 SETBACK MINIMUM REQUIRED (IF NONE SHOWN, A BUILDING CAN BE CONSTRUCTED ON THE BOUNDARY PROVIDED THAT THE BUILDING HEIGHT AND LENGTH REQUIREMENTS ARE MET)

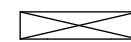

DESIGNATED VEHICLE CROSSOVER TO LOT (NO OTHER VEHICULAR ACCESS POINT IS PERMITTED TO A LOT, EXCEPT WITH THE APPROVAL OF DEVELOPMENT VICTORIA AND WYNDHAM CITY COUNCIL)



CRA SURVEY PTY LTD
LAND SURVEYORS TOWN PLANNERS
DEVELOPMENT CONSULTANTS

7A/346 Belmore Road office@crsurvey.com.au
Balwyn Vic 3103 Tel: 03 9890 0933

REF: 3936BE28

VERSION: 1 (28-10-2019)

SCALE
1 : 400

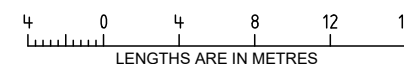

ORIGINAL SHEET
SIZE: A3

SHEET 3 OF 5



RIVERWALK RELEASE 28
BUILDING ENVELOPE PLAN

- Ⓐ BUILDING ENVELOPE BOUNDARY PROFILE TYPE
- 2 SETBACK MINIMUM REQUIRED (IF NONE SHOWN, A BUILDING CAN BE CONSTRUCTED ON THE BOUNDARY PROVIDED THAT THE BUILDING HEIGHT AND LENGTH REQUIREMENTS ARE MET)

2901

LOT NUMBER

PS828101D

----- 3 METRE WIDE EASEMENT

----- 2 OR 2.5 METRE WIDE EASEMENT

DESIGNATED VEHICLE CROSSOVER TO LOT (NO OTHER VEHICULAR ACCESS POINT IS PERMITTED TO A LOT, EXCEPT WITH THE APPROVAL OF DEVELOPMENT VICTORIA AND WYNDHAM CITY COUNCIL)

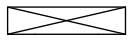
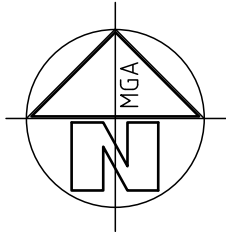

BUILDING ENVELOPE (GROUND FLOOR)



BUILDING ENVELOPE (FIRST FLOOR)

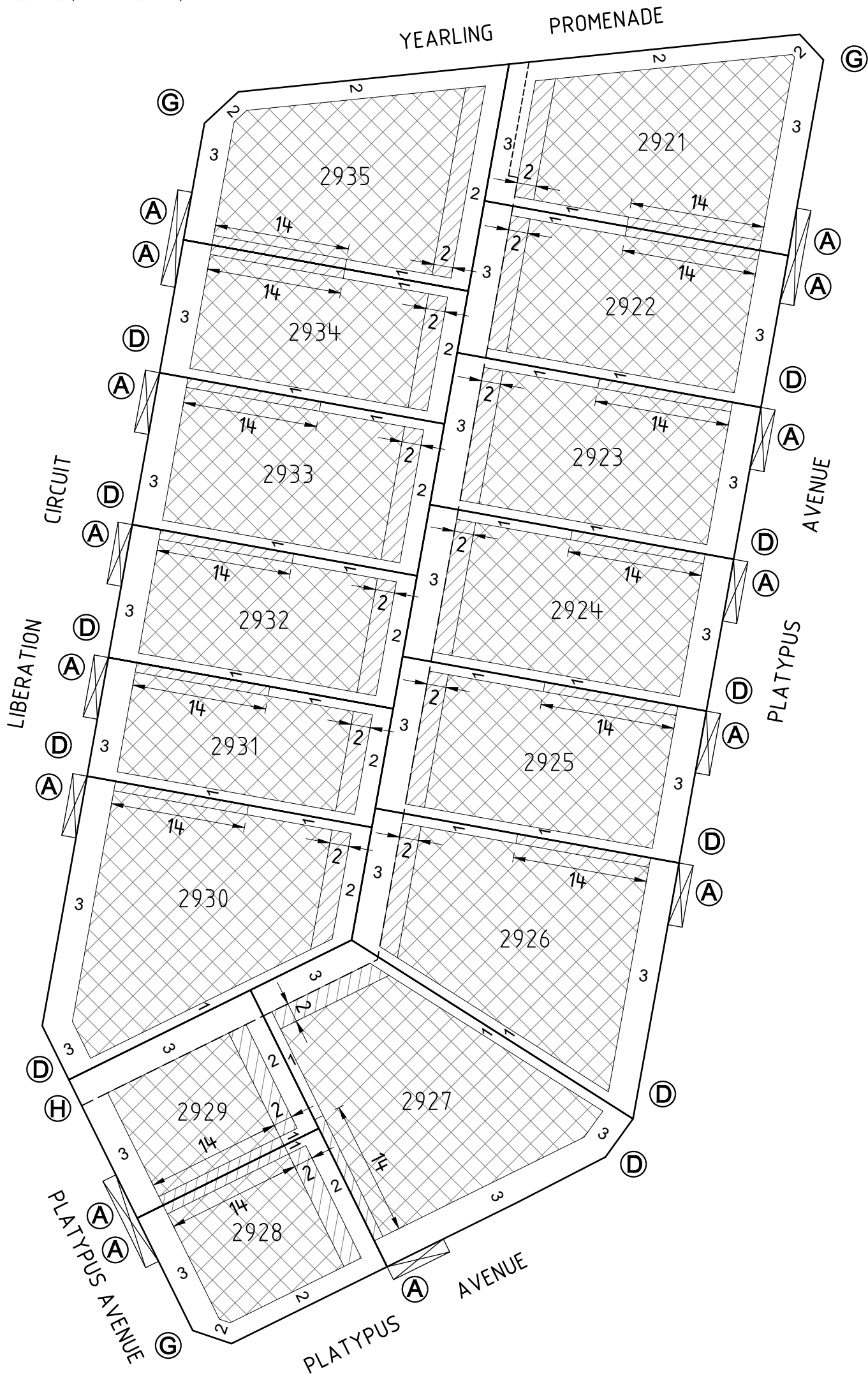

REF: 3936BE29

VERSION: 2 (11-11-2019)



CRA SURVEY PTY LTD

LAND SURVEYORS TOWN PLANNERS
DEVELOPMENT CONSULTANTS

7A/346 Belmore Road office@crsurvey.com.au
Balwyn Vic 3103 Tel: 03 9890 0933

SCALE
1 : 400

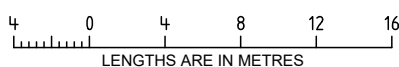



**DEVELOPMENT
VICTORIA**

ORIGINAL SHEET
SIZE: A3

SHEET 4 OF 5

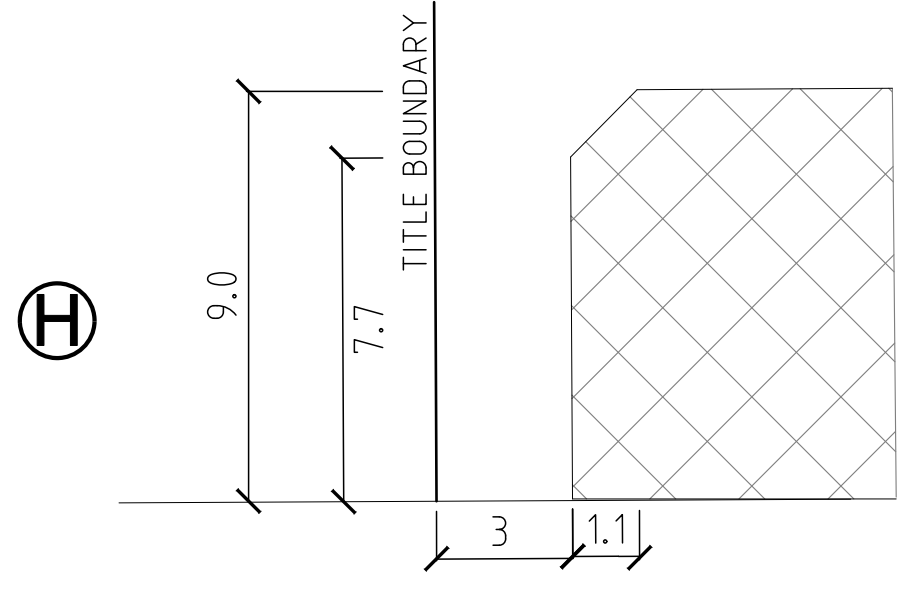
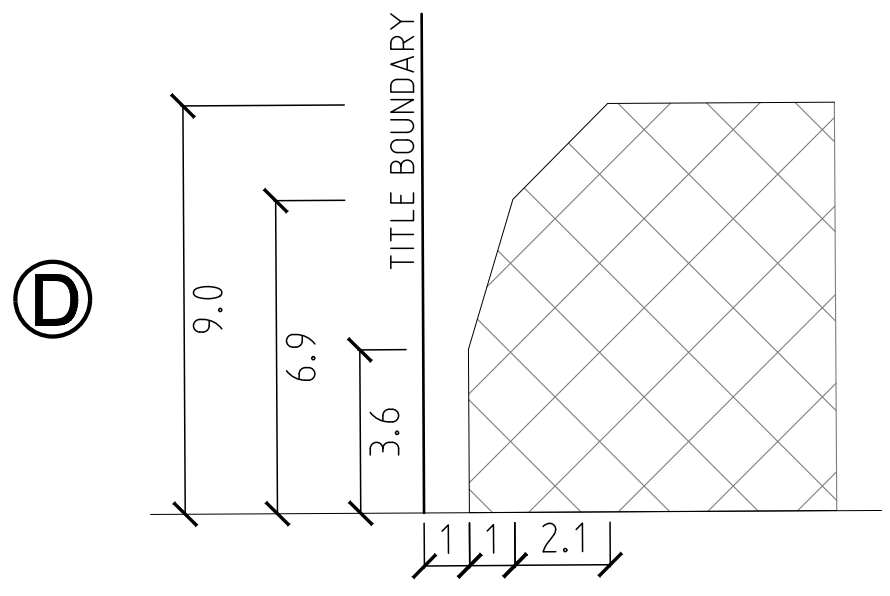
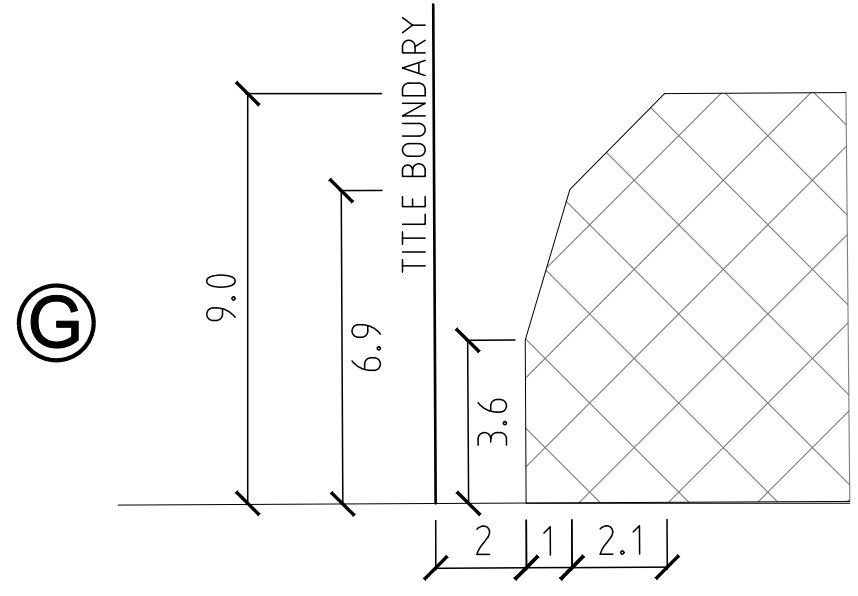
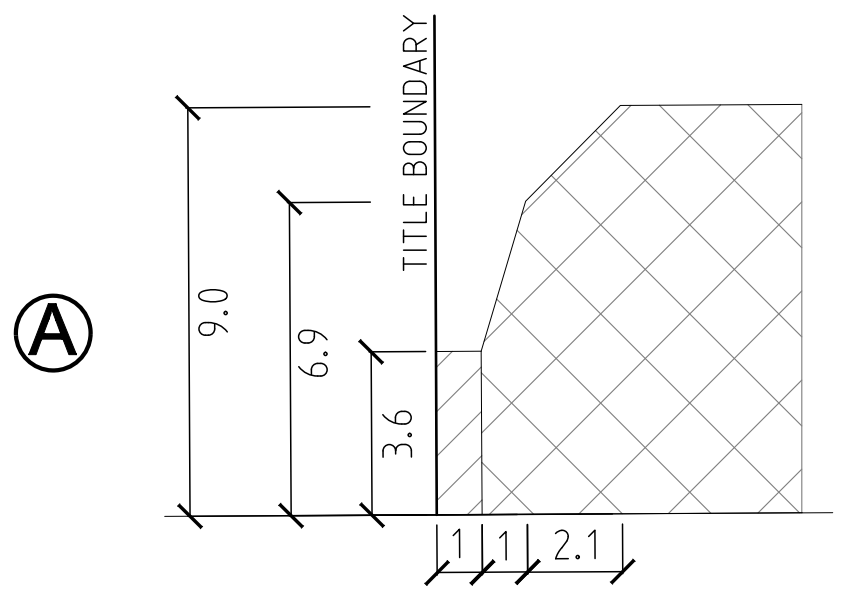
**RIVERWALK RELEASE 29
BUILDING ENVELOPE PLAN**

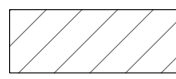

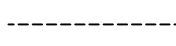
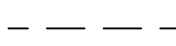
-  BUILDING ENVELOPE (GROUND FLOOR)
-  BUILDING ENVELOPE (FIRST FLOOR)
-  2 OR 2.5 METRE WIDE EASEMENT
-  3 METRE WIDE EASEMENT

2901 LOT NUMBER

- A** BUILDING ENVELOPE BOUNDARY PROFILE TYPE
- 2** SETBACK MINIMUM REQUIRED (IF NONE SHOWN, A BUILDING CAN BE CONSTRUCTED ON THE BOUNDARY PROVIDED THAT THE BUILDING HEIGHT AND LENGTH REQUIREMENTS ARE MET)

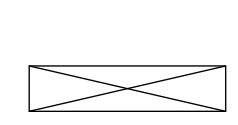

DESIGNATED VEHICLE CROSSOVER TO LOT (NO OTHER VEHICULAR ACCESS POINT IS PERMITTED TO A LOT, EXCEPT WITH THE APPROVAL OF DEVELOPMENT VICTORIA AND WYNDHAM CITY COUNCIL)