

**KEY PLAN**

② - ④ DENOTES SHEET NUMBER REFERENCE

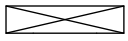

DESIGNATED VEHICLE CROSSOVER TO LOT (NO OTHER VEHICULAR ACCESS POINT IS PERMITTED TO A LOT, EXCEPT WITH THE APPROVAL OF DEVELOPMENT VICTORIA AND WYNDHAM CITY COUNCIL)

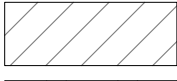

BUILDING ENVELOPE (GROUND FLOOR)



BUILDING ENVELOPE (FIRST FLOOR)

--- 3 METRE WIDE EASEMENT

--- 2 OR 2.5 METRE WIDE EASEMENT

3201 LOT NUMBER

2 SETBACK MINIMUM REQUIRED (IF NONE SHOWN, A BUILDING CAN BE CONSTRUCTED ON THE BOUNDARY PROVIDED THAT THE BUILDING HEIGHT AND LENGTH REQUIREMENTS ARE MET)

(A) BUILDING ENVELOPE BOUNDARY PROFILE TYPE

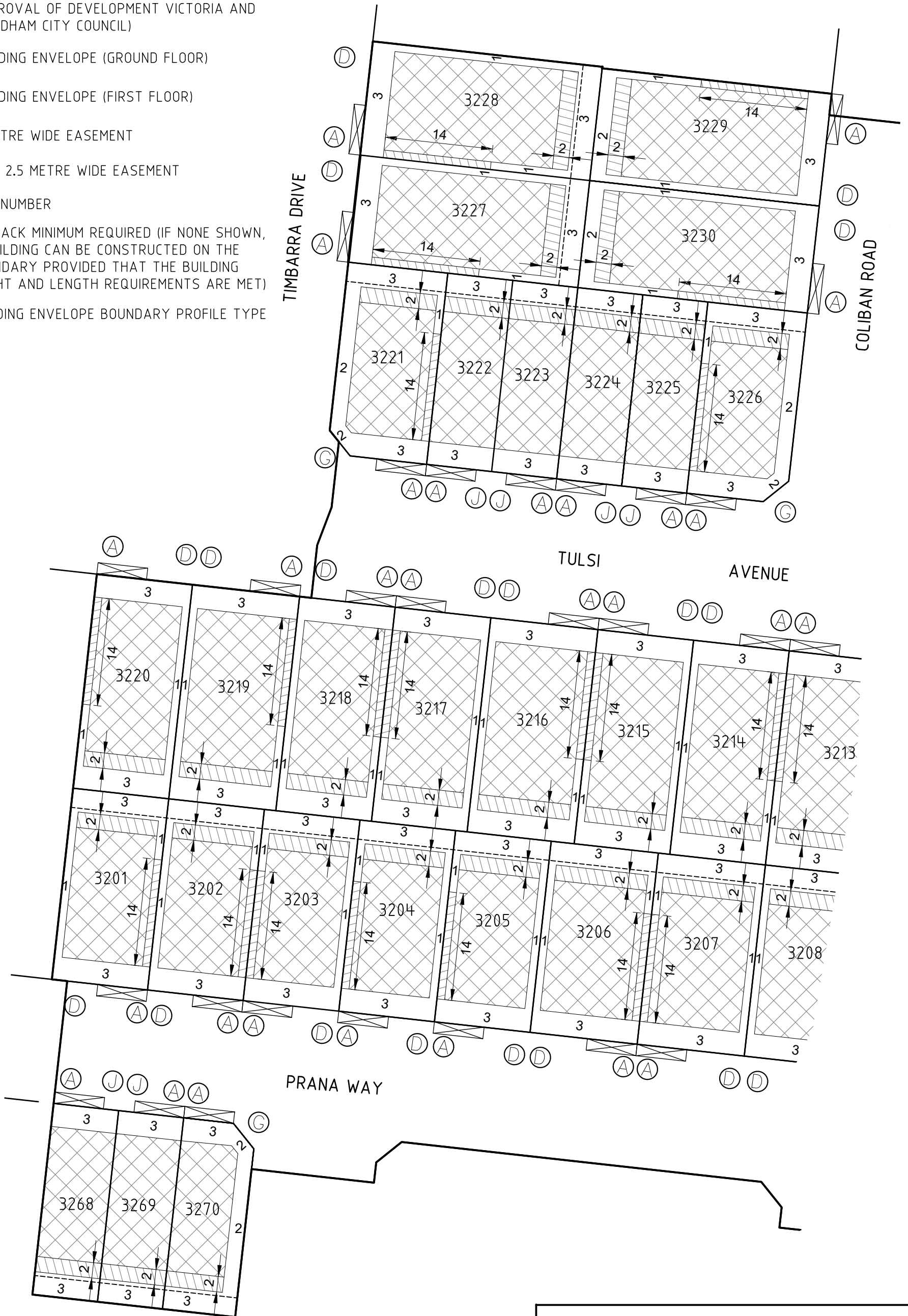
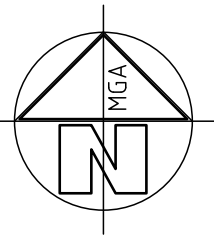

REF: 3936BE32

VERSION: 5 (18.04.2023)



CRA SURVEY PTY LTD

LAND SURVEYORS TOWN PLANNERS  
DEVELOPMENT CONSULTANTS

7A/346 Belmore Road office@crsurvey.com.au  
Balwyn Vic 3103 Tel: 03 9890 0933

SCALE  
1 : 500

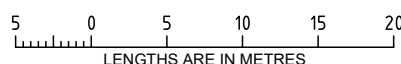

ORIGINAL SHEET  
SIZE: A3

SHEET 2 OF 5

RIVERWALK RELEASE 32  
BUILDING ENVELOPE PLAN

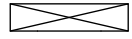

DESIGNATED VEHICLE CROSSOVER TO LOT (NO OTHER VEHICULAR ACCESS POINT IS PERMITTED TO A LOT, EXCEPT WITH THE APPROVAL OF DEVELOPMENT VICTORIA AND WYNDHAM CITY COUNCIL)

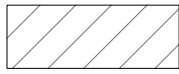

BUILDING ENVELOPE (GROUND FLOOR)

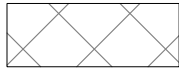

BUILDING ENVELOPE (FIRST FLOOR)

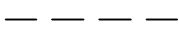

3 METRE WIDE EASEMENT

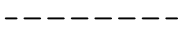

2 OR 2.5 METRE WIDE EASEMENT

3201 LOT NUMBER

2 SETBACK MINIMUM REQUIRED (IF NONE SHOWN, A BUILDING CAN BE CONSTRUCTED ON THE BOUNDARY PROVIDED THAT THE BUILDING HEIGHT AND LENGTH REQUIREMENTS ARE MET)

(A) BUILDING ENVELOPE BOUNDARY PROFILE TYPE

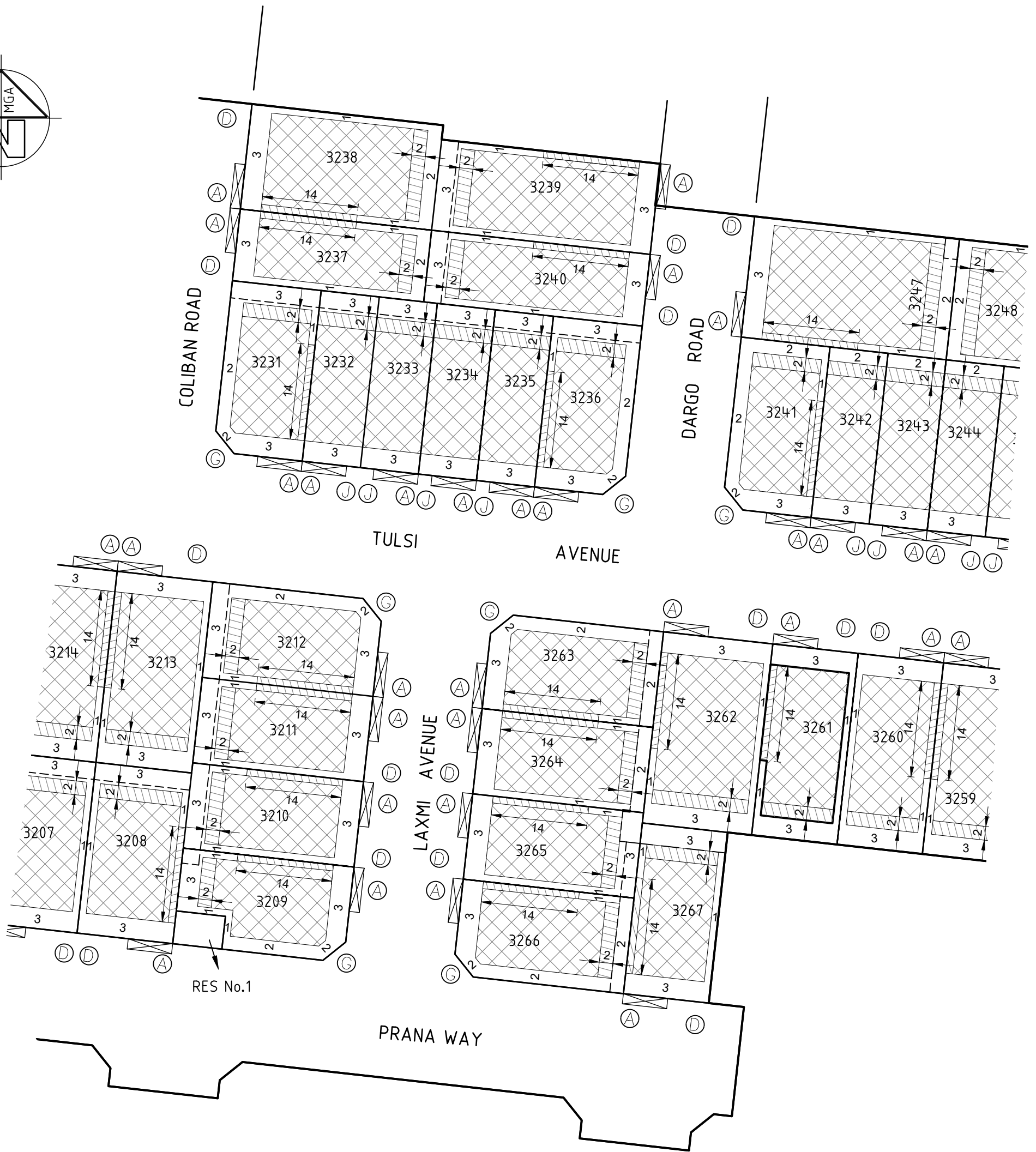
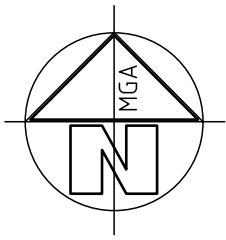

RES No.1

REF: 3936BE32 VERSION: 5 (18.04.2023)

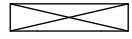

DESIGNATED VEHICLE CROSSOVER TO LOT (NO OTHER VEHICULAR ACCESS POINT IS PERMITTED TO A LOT, EXCEPT WITH THE APPROVAL OF DEVELOPMENT VICTORIA AND WYNDHAM CITY COUNCIL)

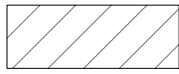

BUILDING ENVELOPE (GROUND FLOOR)



BUILDING ENVELOPE (FIRST FLOOR)

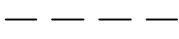

3 METRE WIDE EASEMENT

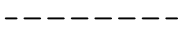

2 OR 2.5 METRE WIDE EASEMENT

3201 LOT NUMBER

2 SETBACK MINIMUM REQUIRED (IF NONE SHOWN, A BUILDING CAN BE CONSTRUCTED ON THE BOUNDARY PROVIDED THAT THE BUILDING HEIGHT AND LENGTH REQUIREMENTS ARE MET)

(A) BUILDING ENVELOPE BOUNDARY PROFILE TYPE

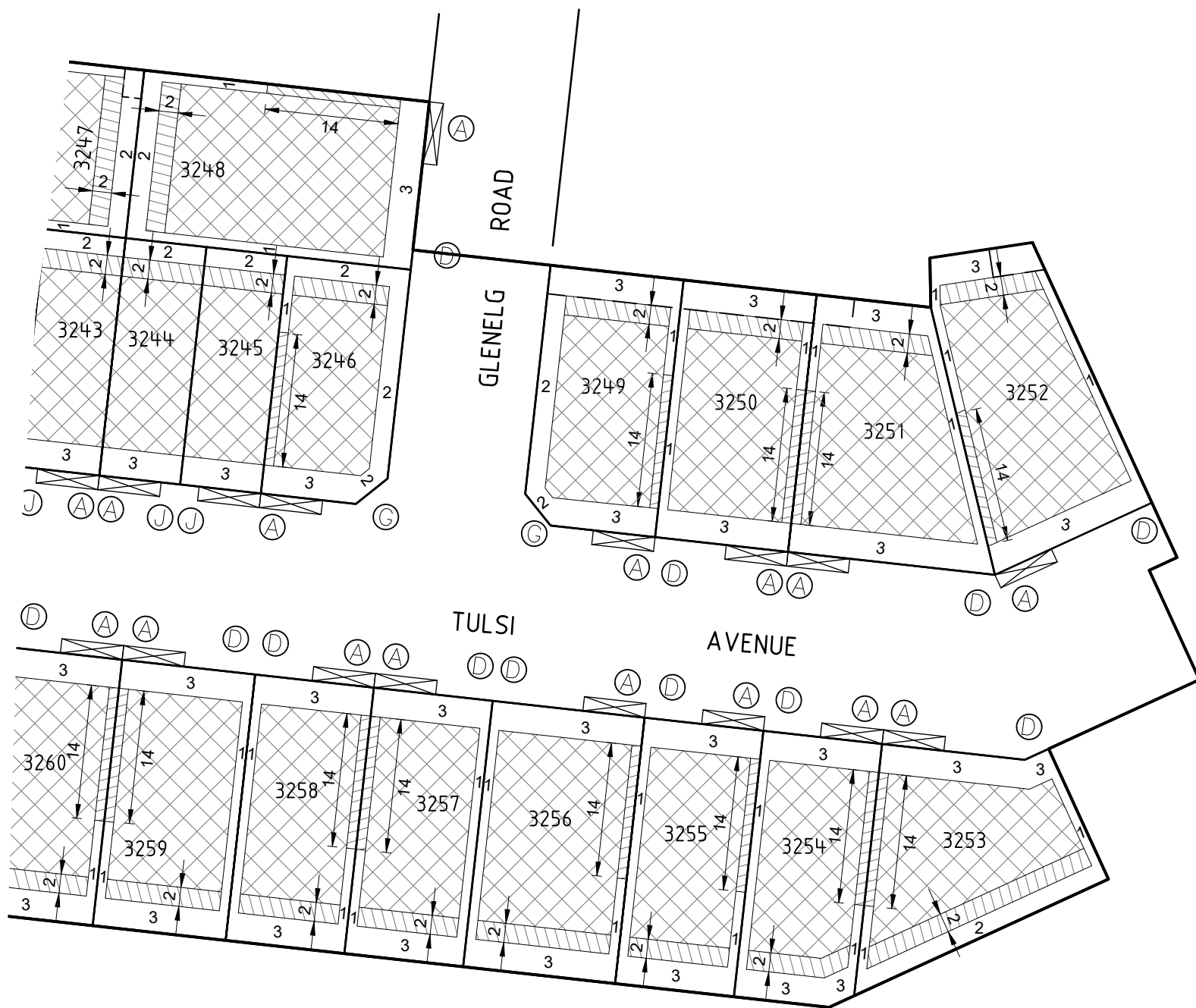
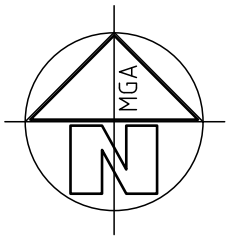

REF: 3936BE32

VERSION: 5 (18.04.2023)



**CRA SURVEY PTY LTD**

LAND SURVEYORS TOWN PLANNERS  
DEVELOPMENT CONSULTANTS

7A/346 Belmore Road office@craurvey.com.au  
Balwyn Vic 3103 Tel: 03 9890 0933

SCALE  
1 : 600

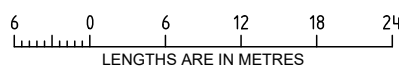



ORIGINAL SHEET  
SIZE: A3

SHEET 4 OF 5

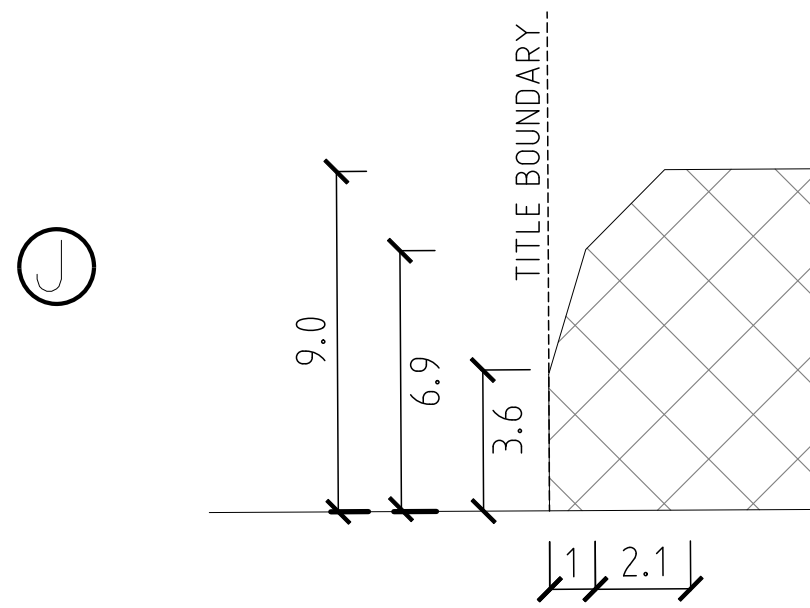
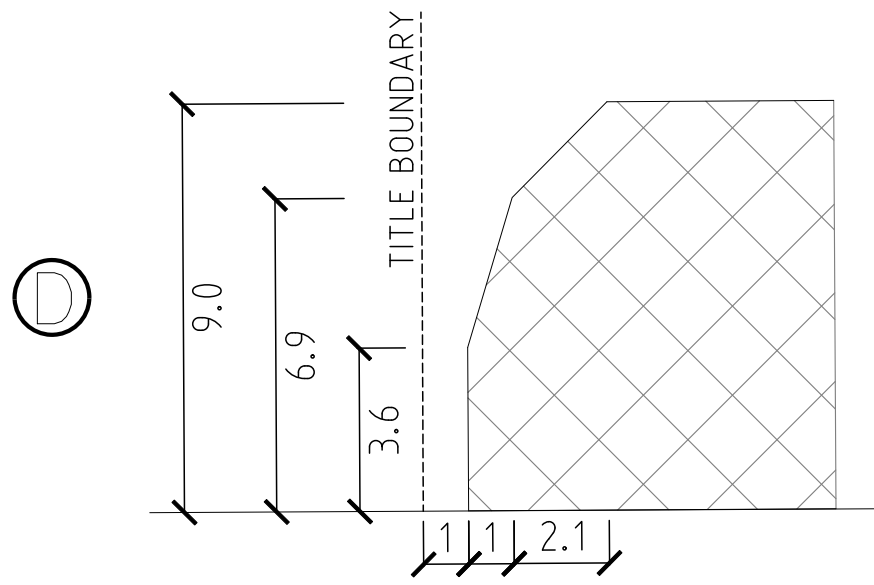
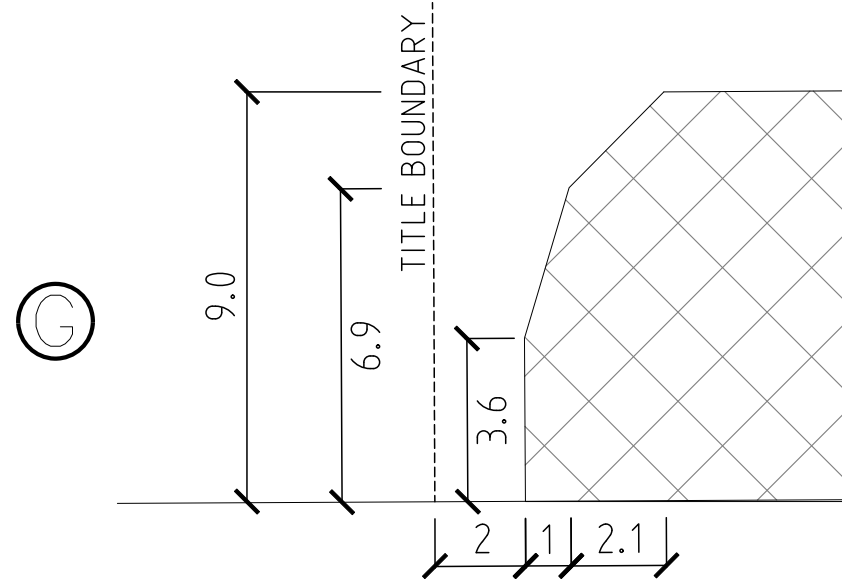
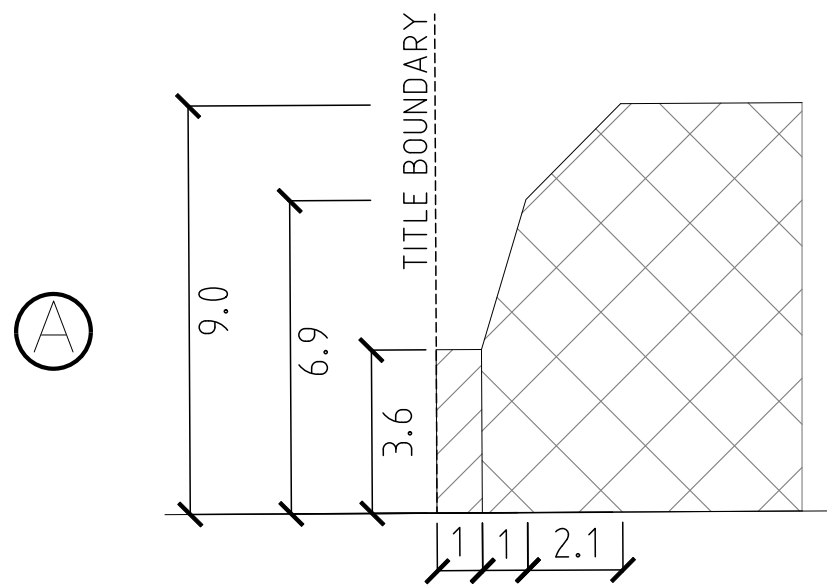
**RIVERWALK RELEASE 32  
BUILDING ENVELOPE PLAN**

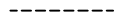
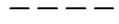

-  BUILDING ENVELOPE (GROUND FLOOR)
-  BUILDING ENVELOPE (FIRST FLOOR)
-  2 OR 2.5 METRE WIDE EASEMENT
-  3 METRE WIDE EASEMENT

**3201** LOT NUMBER

 BUILDING ENVELOPE BOUNDARY PROFILE TYPE  
 2 SETBACK MINIMUM REQUIRED (IF NONE SHOWN, A BUILDING CAN BE CONSTRUCTED ON THE BOUNDARY PROVIDED THAT THE BUILDING HEIGHT AND LENGTH REQUIREMENTS ARE MET)

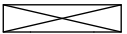
 DESIGNATED VEHICLE CROSSOVER TO LOT (NO OTHER VEHICULAR ACCESS POINT IS PERMITTED TO A LOT, EXCEPT WITH THE APPROVAL OF DEVELOPMENT VICTORIA AND WYNDHAM CITY COUNCIL)