

PS 844473W

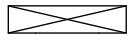

DESIGNATED VEHICLE CROSSOVER TO LOT (NO OTHER VEHICULAR ACCESS POINT IS PERMITTED TO A LOT, EXCEPT WITH THE APPROVAL OF DEVELOPMENT VICTORIA AND WYNDHAM CITY COUNCIL)



BUILDING ENVELOPE (GROUND FLOOR)

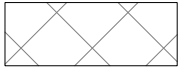

BUILDING ENVELOPE (FIRST FLOOR)

--- 3 METRE WIDE EASEMENT

--- 2 OR 2.5 METRE WIDE EASEMENT

3601 LOT NUMBER

2 SETBACK MINIMUM REQUIRED (IF NONE SHOWN, A BUILDING CAN BE CONSTRUCTED ON THE BOUNDARY PROVIDED THAT THE BUILDING HEIGHT AND LENGTH REQUIREMENTS ARE MET)

(A) BUILDING ENVELOPE BOUNDARY PROFILE TYPE

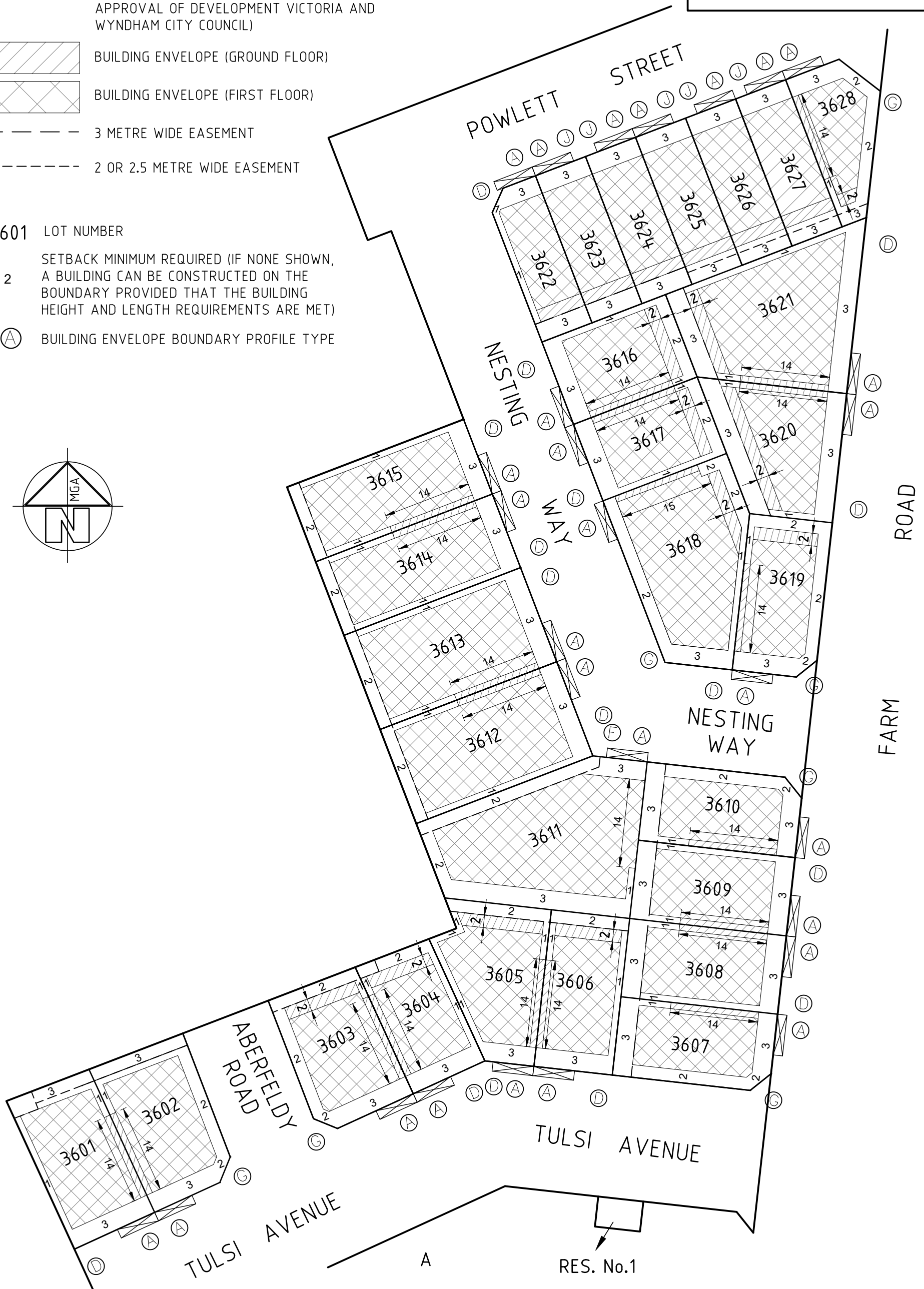
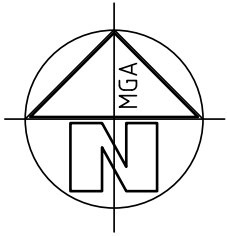

REF: 3936BE36

VERSION: 3 (11.10.2023)



CRA SURVEY PTY LTD

LAND SURVEYORS TOWN PLANNERS  
DEVELOPMENT CONSULTANTS

7A/346 Belmore Road office@crasurvey.com.au  
Balwyn Vic 3103 Tel: 03 9890 0933

SCALE  
1 : 600

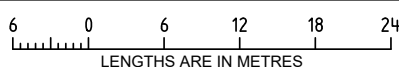



ORIGINAL SHEET  
SIZE: A3

SHEET 1 OF 2

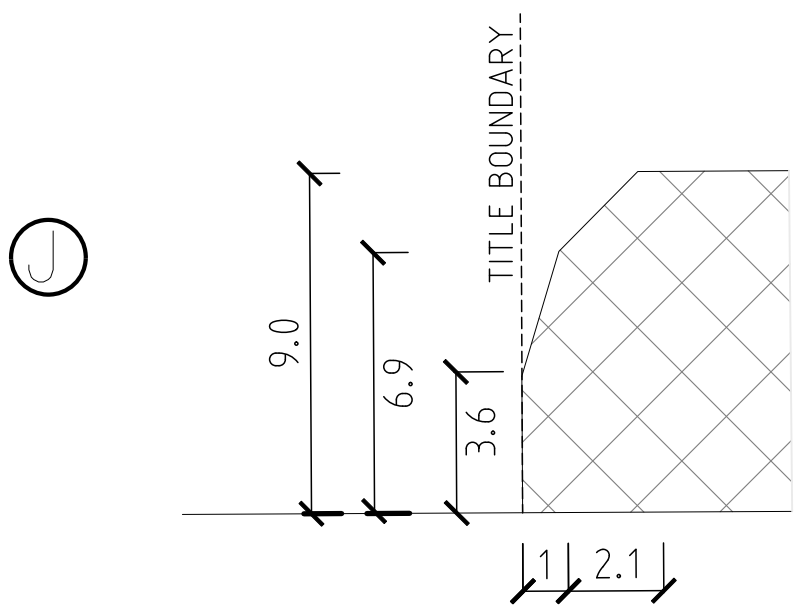
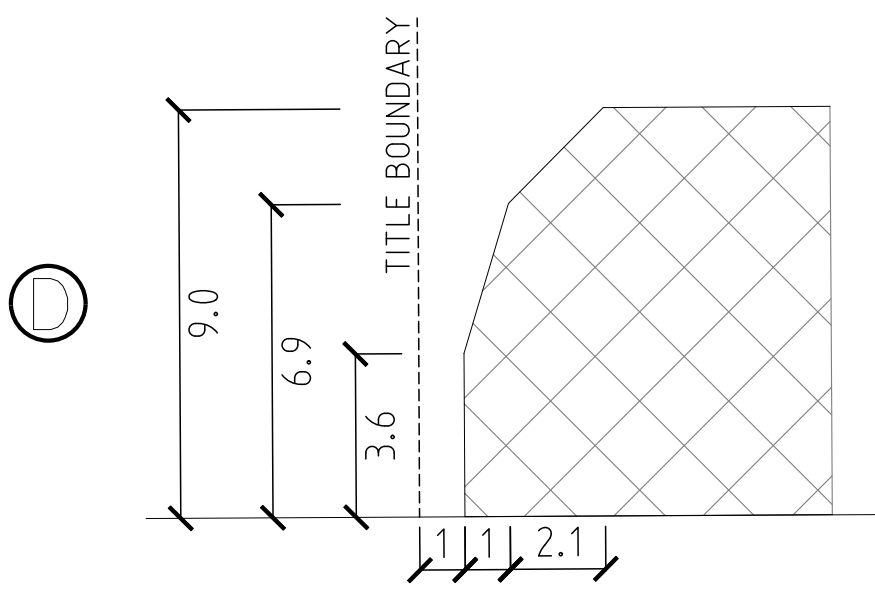
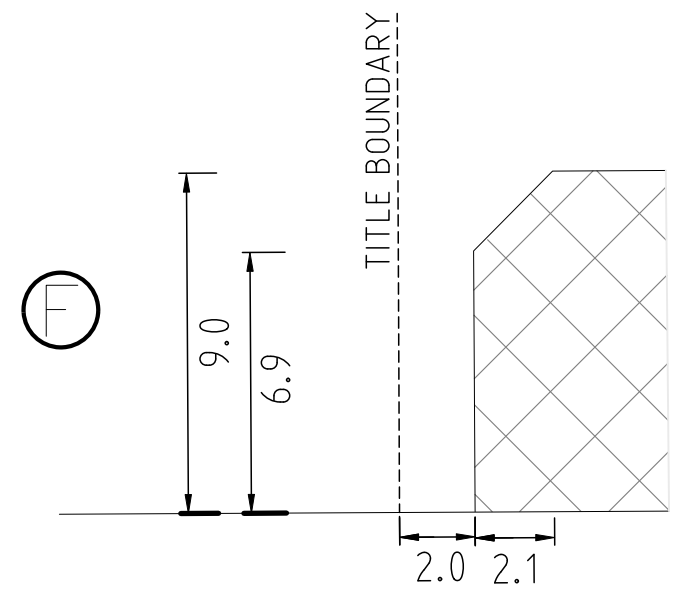
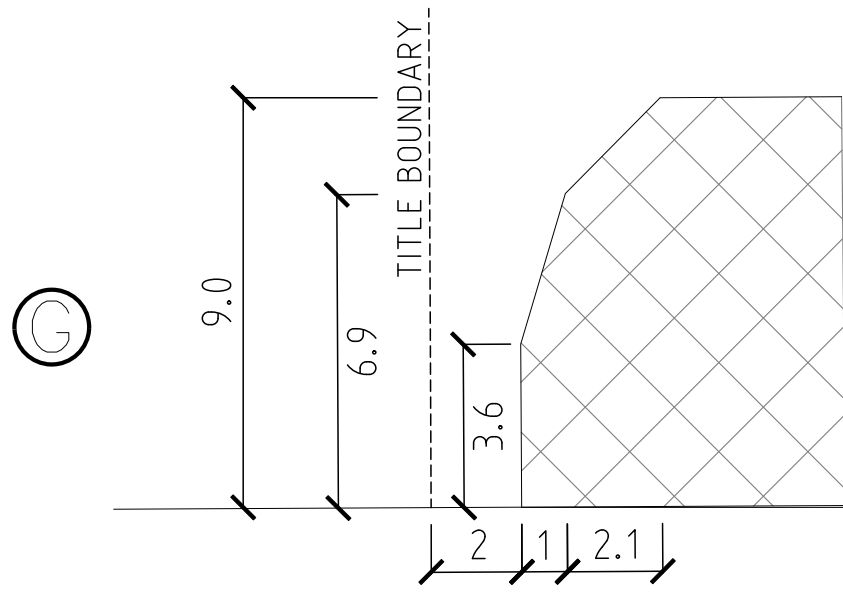
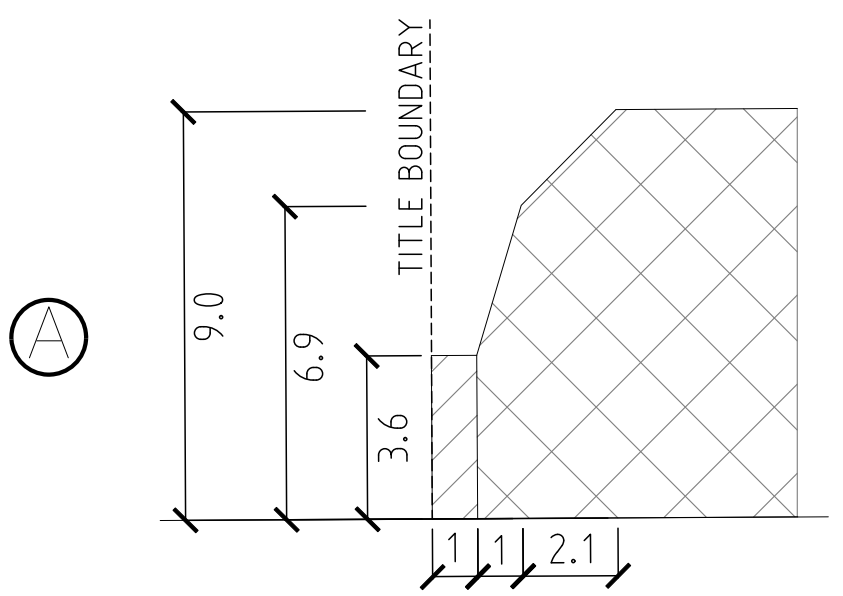
RIVERWALK RELEASE 36  
BUILDING ENVELOPE PLAN

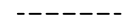
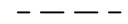

-  BUILDING ENVELOPE (GROUND FLOOR)
-  BUILDING ENVELOPE (FIRST FLOOR)
-  2 OR 2.5 METRE WIDE EASEMENT
-  3 METRE WIDE EASEMENT

**3601** LOT NUMBER

**A** BUILDING ENVELOPE BOUNDARY PROFILE TYPE  
 SETBACK MINIMUM REQUIRED (IF NONE SHOWN, A BUILDING CAN BE CONSTRUCTED ON THE BOUNDARY PROVIDED THAT THE BUILDING HEIGHT AND LENGTH REQUIREMENTS ARE MET)

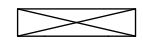
 DESIGNATED VEHICLE CROSSOVER TO LOT (NO OTHER VEHICULAR ACCESS POINT IS PERMITTED TO A LOT, EXCEPT WITH THE APPROVAL OF DEVELOPMENT VICTORIA AND WYNDHAM CITY COUNCIL)