

KEY PLAN

② - ④ DENOTES SHEET NUMBER REFERENCE

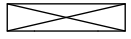

DESIGNATED VEHICLE CROSSOVER TO LOT (NO OTHER VEHICULAR ACCESS POINT IS PERMITTED TO A LOT, EXCEPT WITH THE APPROVAL OF DEVELOPMENT VICTORIA AND WYNDHAM CITY COUNCIL)

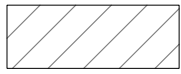

BUILDING ENVELOPE (GROUND FLOOR)

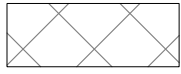

BUILDING ENVELOPE (FIRST FLOOR)

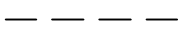

3 METRE WIDE EASEMENT

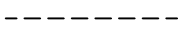

2 OR 2.5 METRE WIDE EASEMENT

3301 LOT NUMBER

2 SETBACK MINIMUM REQUIRED (IF NONE SHOWN, A BUILDING CAN BE CONSTRUCTED ON THE BOUNDARY PROVIDED THAT THE BUILDING HEIGHT AND LENGTH REQUIREMENTS ARE MET)

(A) BUILDING ENVELOPE BOUNDARY PROFILE TYPE

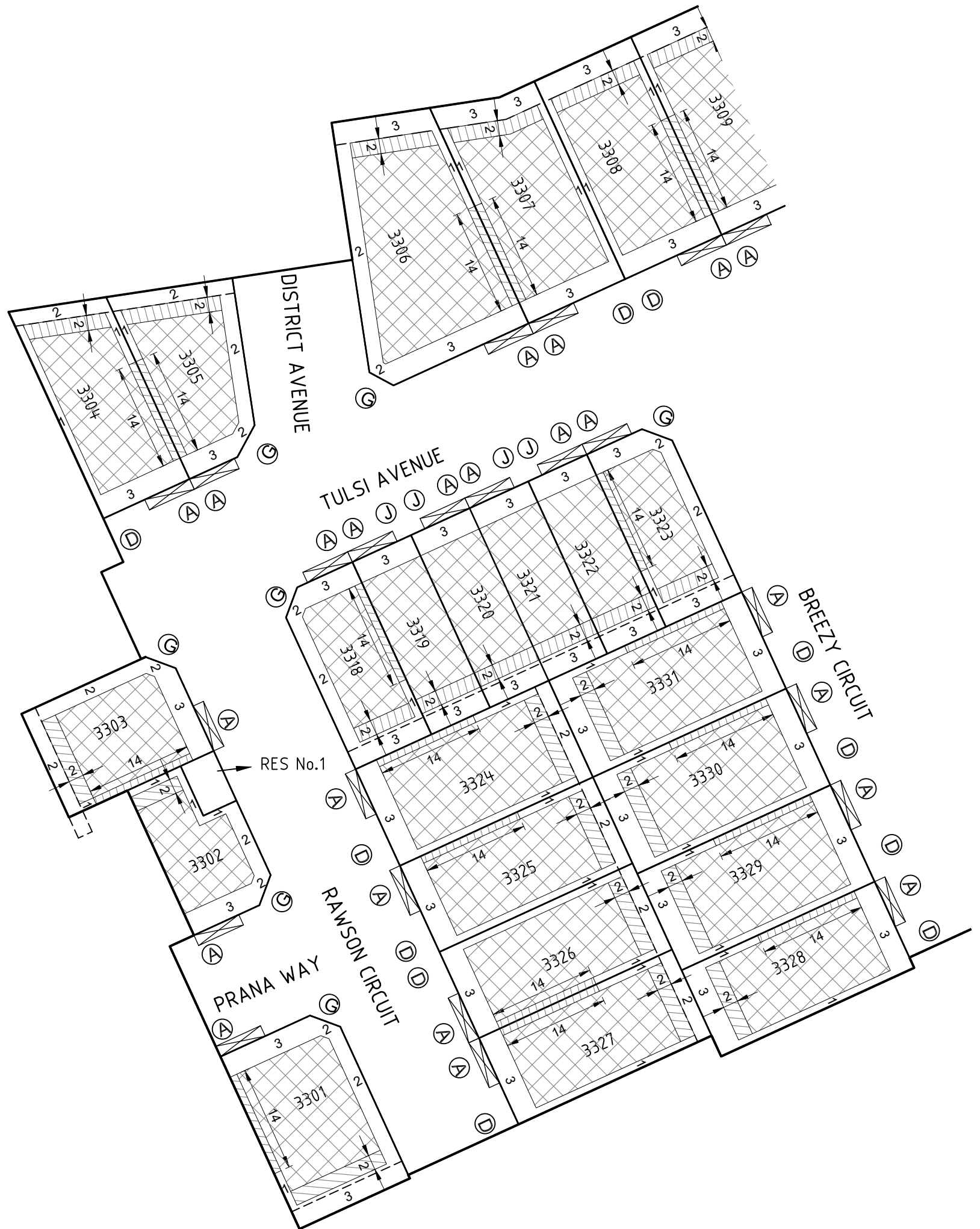
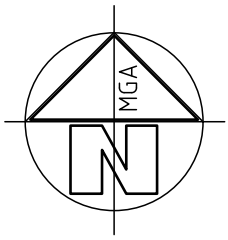

REF: 3936BE33

VERSION: 2 (30.09.2021)

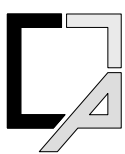

**CRA SURVEY PTY LTD**

LAND SURVEYORS TOWN PLANNERS  
DEVELOPMENT CONSULTANTS

7A/346 Belmore Road office@crasurvey.com.au  
Balwyn Vic 3103 Tel: 03 9890 0933

SCALE  
1 : 600

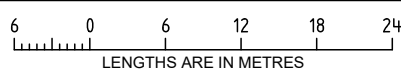

ORIGINAL SHEET  
SIZE: A3

SHEET 2 OF 5

**RIVERWALK RELEASE 33  
BUILDING ENVELOPE PLAN**

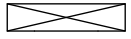

DESIGNATED VEHICLE CROSSOVER TO LOT (NO OTHER VEHICULAR ACCESS POINT IS PERMITTED TO A LOT, EXCEPT WITH THE APPROVAL OF DEVELOPMENT VICTORIA AND WYNDHAM CITY COUNCIL)



BUILDING ENVELOPE (GROUND FLOOR)

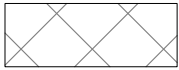

BUILDING ENVELOPE (FIRST FLOOR)

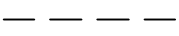

3 METRE WIDE EASEMENT

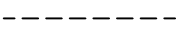

2 OR 2.5 METRE WIDE EASEMENT

3301 LOT NUMBER

2 SETBACK MINIMUM REQUIRED (IF NONE SHOWN, A BUILDING CAN BE CONSTRUCTED ON THE BOUNDARY PROVIDED THAT THE BUILDING HEIGHT AND LENGTH REQUIREMENTS ARE MET)

(A) BUILDING ENVELOPE BOUNDARY PROFILE TYPE

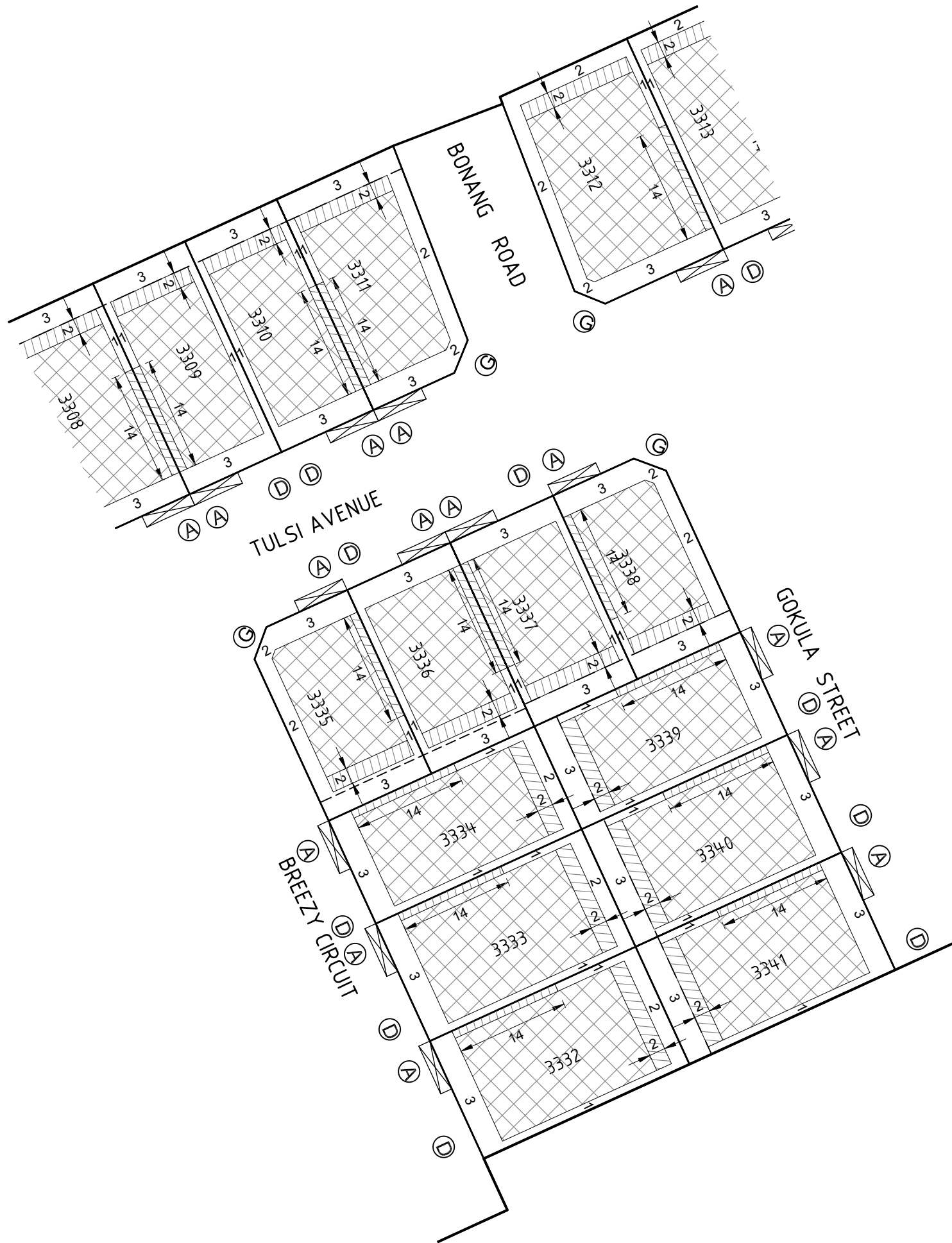
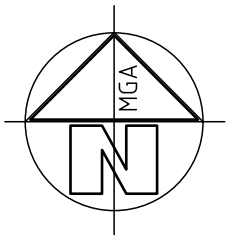

REF: 3936BE33      VERSION: 2 (30.09.2021)

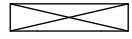

DESIGNATED VEHICLE CROSSOVER TO LOT (NO OTHER VEHICULAR ACCESS POINT IS PERMITTED TO A LOT, EXCEPT WITH THE APPROVAL OF DEVELOPMENT VICTORIA AND WYNDHAM CITY COUNCIL)

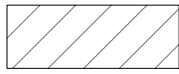

BUILDING ENVELOPE (GROUND FLOOR)



BUILDING ENVELOPE (FIRST FLOOR)

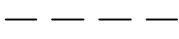

3 METRE WIDE EASEMENT

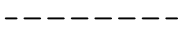

2 OR 2.5 METRE WIDE EASEMENT

3301 LOT NUMBER

2 SETBACK MINIMUM REQUIRED (IF NONE SHOWN, A BUILDING CAN BE CONSTRUCTED ON THE BOUNDARY PROVIDED THAT THE BUILDING HEIGHT AND LENGTH REQUIREMENTS ARE MET)

(A) BUILDING ENVELOPE BOUNDARY PROFILE TYPE

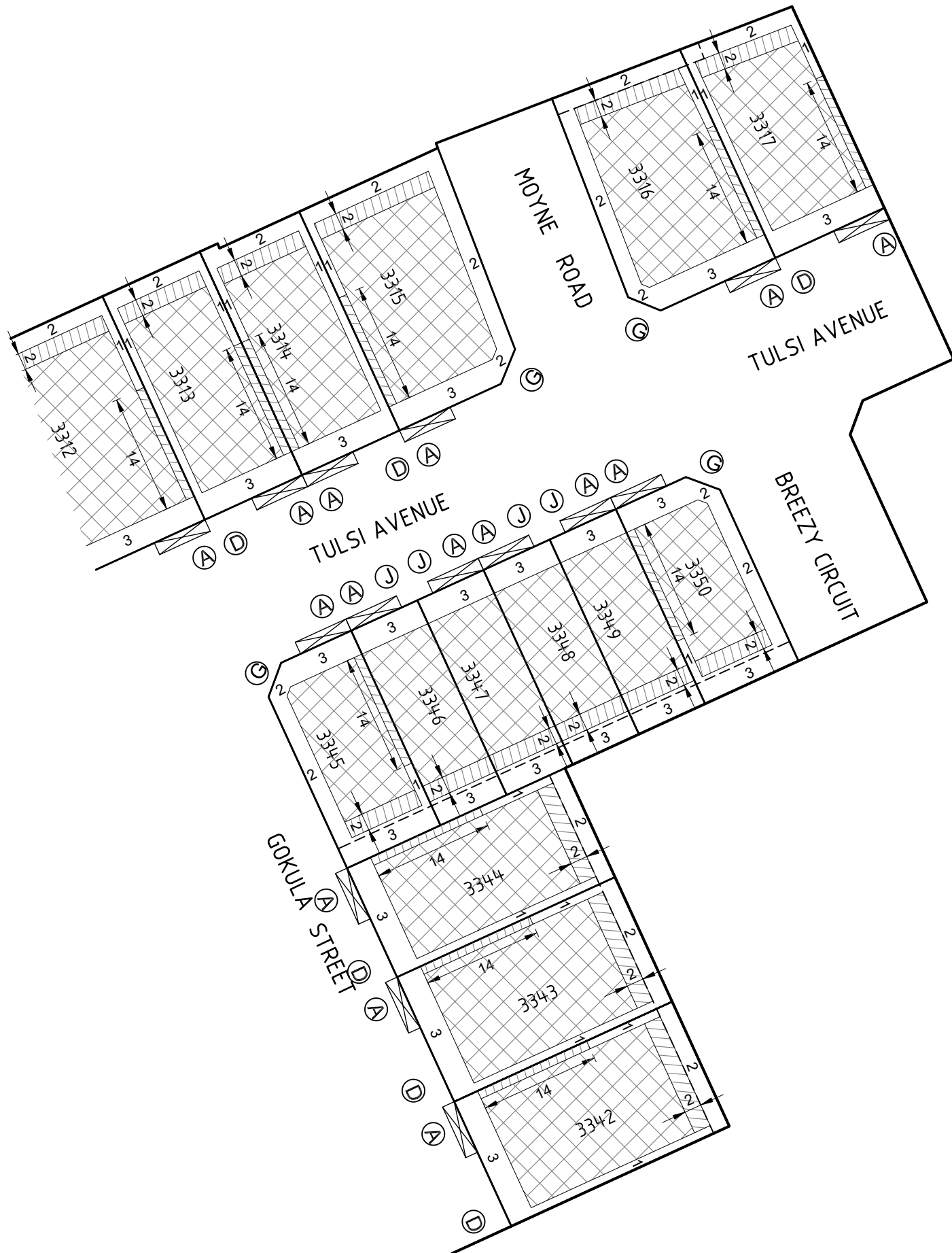
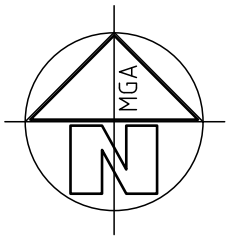



REF: 3936BE33 VERSION: 2 (30.09.2021)

**CRA SURVEY PTY LTD**  
 LAND SURVEYORS TOWN PLANNERS  
 DEVELOPMENT CONSULTANTS  
 7A/346 Belmore Road office@craurvey.com.au  
 Balwyn Vic 3103 Tel: 03 9890 0933

SCALE 1 : 600  
  
 LENGTHS ARE IN METRES

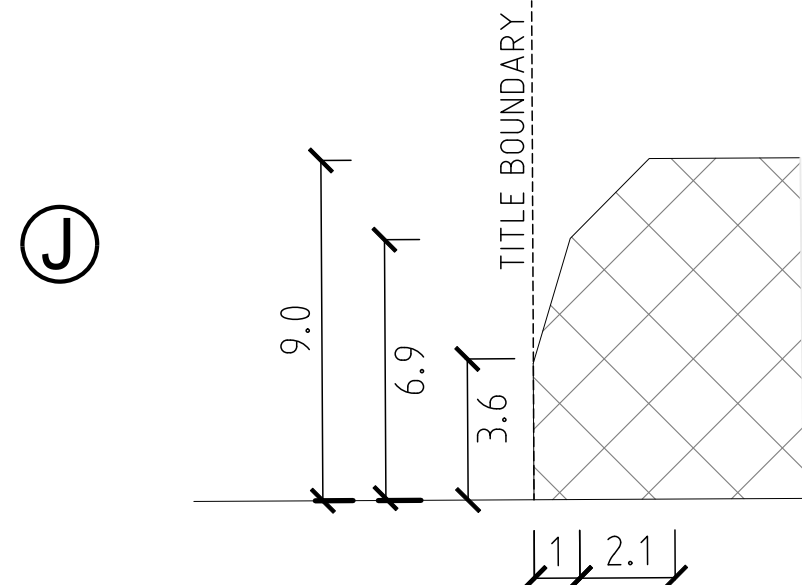
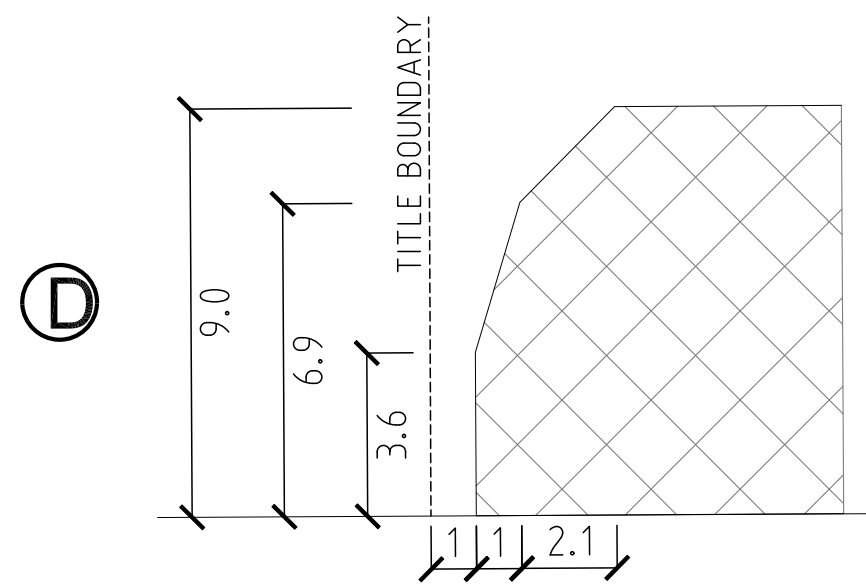
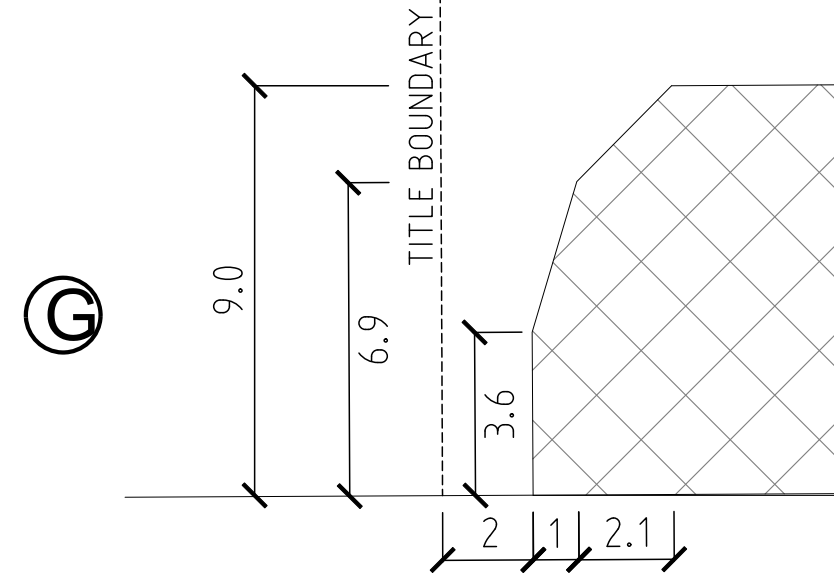
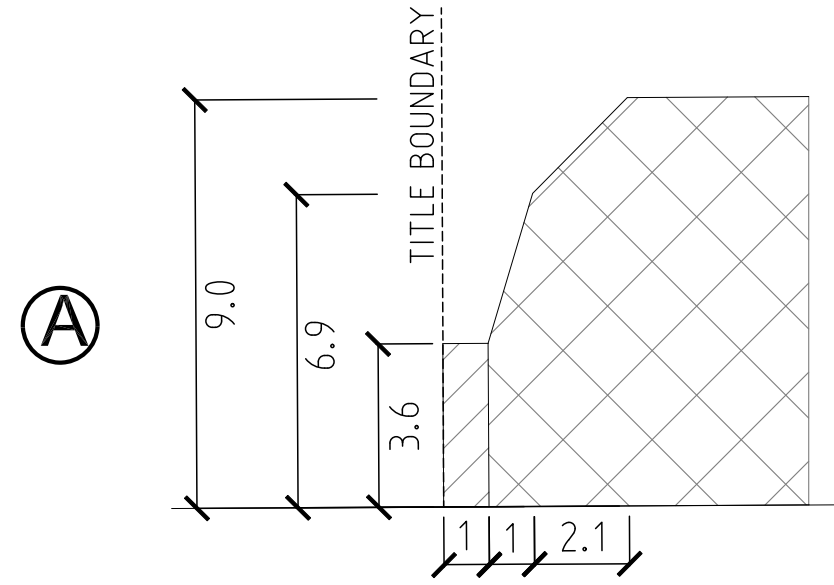
ORIGINAL SHEET SIZE: A3 SHEET 4 OF 5  
**RIVERWALK RELEASE 33**  
**BUILDING ENVELOPE PLAN**

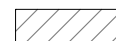

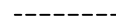
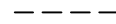
-  BUILDING ENVELOPE (GROUND FLOOR)
-  BUILDING ENVELOPE (FIRST FLOOR)
-  2 OR 2.5 METRE WIDE EASEMENT
-  3 METRE WIDE EASEMENT

3301 LOT NUMBER

**(A)** BUILDING ENVELOPE BOUNDARY PROFILE TYPE  
 SETBACK MINIMUM REQUIRED (IF NONE SHOWN,  
 A BUILDING CAN BE CONSTRUCTED ON THE  
 BOUNDARY PROVIDED THAT THE BUILDING  
 HEIGHT AND LENGTH REQUIREMENTS ARE MET)

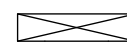

DESIGNATED VEHICLE CROSSOVER TO LOT (NO  
 OTHER VEHICULAR ACCESS POINT IS  
 PERMITTED TO A LOT, EXCEPT WITH THE  
 APPROVAL OF DEVELOPMENT VICTORIA AND  
 WYNDHAM CITY COUNCIL)